

ChemFeed Metering Pump Model 340-0200

ChemFeed Metering Pump



Features:

- Double Ball Inlet and Outlet Cartridge-type check valves
- Precision Molded Polypropylene heavy-duty pump head
- Diaphragm material is Teflon coated EP
- Long Life mechanical feed rate adjustment mechanism
- Wide range of outputs to choose from

Product Description:

The Feed Metering Pump to a variety of chemical feed applications. It has a heavy duty head with bullet cartridge valves constructed of tough PVDF. Each valve has two ceramic checks which are double sealed with high grade Viton and TFE/P o rings. The double ball valve design provides enhanced priming and is exceptional for purging air and gas. It has a dial-type, top mounted output control.

Specifications:

Max Pressure	125 psig/8.6 bar
Max fluid Temperature	130° F/54° C
Max Viscosity	1,000 Centipoise
Max suction lift	10 ft. Water
Duty Cycle	Continuous
Enclosure	NEMA 3R (IP23)
Power	Standard 115V/60Hz Optional 230V/50Hz
Shipping weight	8 lbs/3.64kg

Dimensional Drawing:

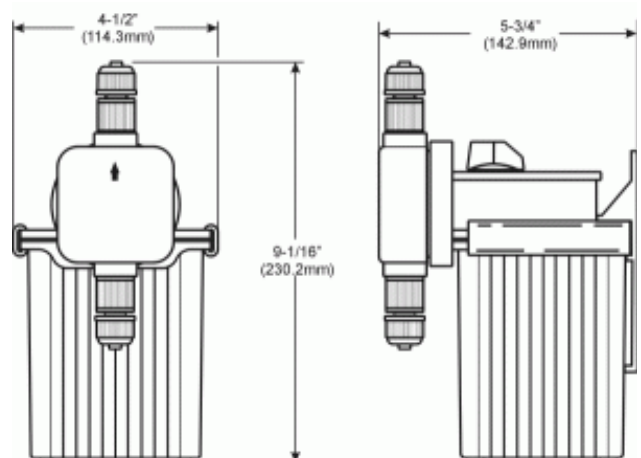

Authorized Distributor: